

Instrument to collect fogwater for chemical analysis

Daniel J. Jacob,^{a)} Jed M. Waldman, Mehrdad Haghi,^{b)} Michael R. Hoffmann, and Richard C. Flagan^{c)}

Environmental Engineering Science, W. M. Keck Engineering Laboratories, California Institute of Technology, Pasadena, California 91125

(Received 2 January 1985; accepted for publication 16 February 1985)

An instrument is presented which collects large samples of ambient fogwater by impaction of droplets on a screen. The collection efficiency of the instrument is determined as a function of droplet size, and it is shown that fog droplets in the range 3–100- μm diameter are efficiently collected. No significant evaporation or condensation occurs at any stage of the collection process. Field testing indicates that samples collected are representative of the ambient fogwater. The instrument may easily be automated, and is suitable for use in routine air quality monitoring programs.

INTRODUCTION

Under supersaturated conditions in the atmosphere, fog droplets form by activation of condensation nuclei¹ and rapidly grow to sufficiently large diameters (1–100 μm) that the deposition to vegetation canopies is considerably enhanced.² Recent reports of extremely high acidities in fogs, and clouds intercepting mountain slopes, have raised concern regarding related environmental consequences.³ Air quality control agencies in areas exposed to acidic fog have expressed the need to establish networks of sites monitoring the chemical composition of fog on a routine basis. A fogwater sampler to be used in such programs must meet four basic requirements: (1) efficiency collect fog droplets in the 1–100- μm size window while avoiding collection of the sub-micron nonactivated aerosol, (2) preserve the size and chemical composition of fog droplets through all stages of collection, (3) rapidly collect large amounts of liquid water for wet chemical analysis, (4) be automated, inexpensive to construct, and require minimal maintenance. A recent paper from our group⁴ has elaborated on design criteria for fogwater collectors, and reported that none of the currently available instruments is satisfactory in all respects. A rotating arm collector developed in our laboratory⁴ has been shown to provide samples representative of the ambient fogwater,⁵ but it is not suitable for automation and presents safety problems. We describe herein a collector that we have recently developed explicitly to provide a simple, reliable, and inexpensive instrument for routine monitoring.

I. DESIGN

The instrument (shown in Fig. 1) collects fogwater by inertial impaction of fog droplets on a screen. The screen is made of two layers of 330- μm -diameter Teflon monofilament strung vertically on a frame between two Teflon-coated threaded rods [Fig. 1(c)]. It is placed at an incline ($\theta = 35^\circ$) in a square duct, through which a blower samples ambient fog-laden air at a velocity $U_s = 9 \text{ m s}^{-1}$. The pressure drop across the screen is 87 Pa. The residence time of impacted droplets on the screen is considerably shortened by placing the screen at an incline instead of vertically, because aerodynamic drag pushes the droplets to the bottom of the screen.

Further, inclining the screen at 35° prevents resuspension of impacted droplets into the air flow, which would occur if the screen was placed vertically.⁶ Accumulation of water on the screen proceeds by formation of large droplets spaced at intervals along the Teflon strings; these droplets rapidly grow large enough (about 1–2-mm diameter) to flow down. A Teflon funnel drains the fogwater collected at the bottom of the screen into a storage bottle directly below. The instrument is set on a platform surmounted by a wind vane so that the inlet is oriented into the wind at all times. Automation of instrument start up may be provided by a number of methods.

The flow of air through the duct is $22 \text{ m}^3 \text{ min}^{-1}$, but only a fraction of that air is actually sampled because of the spacing between strings. Based on the dry diameter of the strings, each of the two layers samples 42% of the air flowing through the duct, and the sampling efficiency of the instrument is about $[1 - (0.58)^2] = 66\%$. In practice, accumulation of water on the strings will slightly increase the impaction surface area and, therefore, the amount of air sampled. About 90 ml of sample is collected per hour in a fog of typical liquid water content 0.1 g m^{-3} . This is sufficient for most analytical purposes.

The principle of operation is that inertia prevents droplets approaching the strings from following the curved flow streamlines around the strings. The deviations of droplet trajectories increase with droplet inertia, and droplets above a certain size deviate sufficiently to collect on the strings. The efficiency of this process is characterized by the Stokes number⁷ St :

$$St = \frac{\rho D^2 U_s \cos \theta}{18 \mu R}, \quad (1)$$

where ρ is the density of the droplet, D is the droplet diameter, μ is the viscosity of air, and R is the radius of the string. The Reynolds number of the flow through the duct is sufficiently high (10^5), and the Mach number is sufficiently low (0.03), that the collection efficiency can be satisfactorily described as solely a function of St and the droplet Reynolds number Re_D .^{7,8} Experimental data is available for the collection efficiency of particles on cylinders as a function of these two dimensionless groups.⁸ For 1–100- μm -diameter droplets, St ranges from 0.14–1400 and Re_D from 0.5–50.

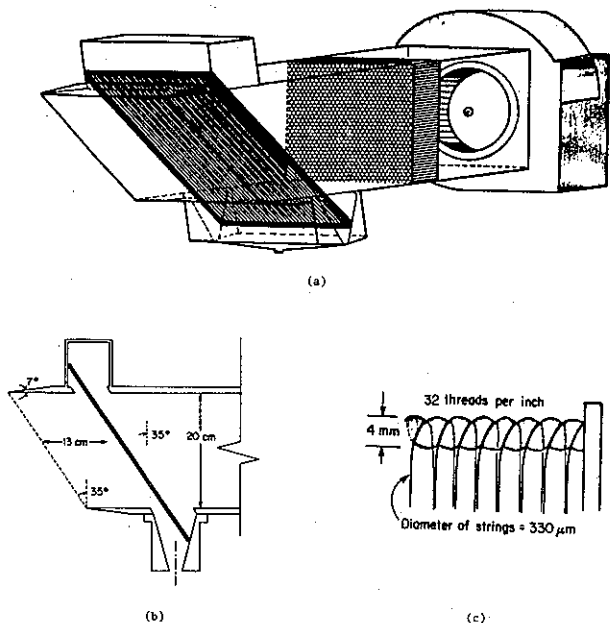

FIG. 1. Screen collector to sample fogwater for chemical analysis. Air is aspirated through a square duct at a rate of $22 \text{ m}^3 \text{ min}^{-1}$ (blower: model 80A, 1/3 HP 115V motor, Central Blower Co., City of Industry, CA). Fog droplets impact on Teflon FEP monofilament (13 mils, Dupont de Nemours Corp.) strung vertically on a brass frame between two Teflon-coated threaded brass rods. Fogwater collected on the strings flows down to a Teflon funnel and a polyethylene bottle directly underneath. (a) Perspective view of the instrument, (b) side view (section), (c) detail of the screen frame.

Because U_s differs from the ambient wind U_a , the flow approaching the inlet is deflected. Large droplets cannot follow the air flow, resulting in an anisokinetic sampling bias at the upper end of the size distribution. To minimize this bias, the instrument must be oriented into the wind at all times. Anisokinetic biases for an inlet oriented into the wind have been documented in detail^{9,10} as a function of U_s/U_a and the inlet Stokes number St_i , [defined by Eq. (1) when the string radius R is replaced by the half-width of the inlet]. In the special case $U_s = U_a$ (isokinetic sampling), no bias is observed. For $U_s/U_a > 1$ the collection efficiency for large droplets is less than 100% (negative bias), and goes through a St_i -dependent minimum at $U_s/U_a \approx 3$ (maximum deflection of the flow streamlines). At the limit $U_s/U_a \rightarrow \infty$, the flow streamlines are straight and no bias is observed. For $U_s/U_a < 1$, the collection efficiency for large droplets is larger than 100% (positive bias), because the flow is deflected away from the inlet. At very large St_i values, the collection efficiency approaches a limit equal to U_a/U_s .

Sampling may also be biased if the droplets shatter upon high-velocity impact on the strings. Droplet shattering may be expected if the Weber number

$$We = \frac{\rho D U_c^2}{\sigma} \quad (2)$$

exceeds about 150.¹¹ U_c is the velocity of the droplet upon impact ($U_c < U_s$), and σ is the surface tension of the droplet-air interface. For a $100\text{-}\mu\text{m}$ -diameter droplet, we find $We < 110$, below the critical value for droplet shattering. Droplet shattering may be expected for droplets larger than about $140\text{-}\mu\text{m}$ diameter, but this is beyond the usual fog size range.

The collection efficiency of our instrument was determined as a function of droplet size from the data of Refs. 8–10, for various ambient wind velocities and an inlet oriented into the wind (Fig. 2). The impaction Stokes number was calculated by taking R equal to the radius of the dry strings. Droplets in the range $3\text{--}100\text{-}\mu\text{m}$ diameter are efficiently collected. Droplets in the size window $10\text{--}30\text{-}\mu\text{m}$ diameter, which typically account for over 95% of the total liquid water content in fog,¹² are collected with over 90% efficiency under all sampling conditions. Fog droplets below $3\text{ }\mu\text{m}$ are poorly collected, but represent only a very small fraction of the total suspended liquid water. Collection of submicron aerosol by convective diffusion to the strings is very inefficient: the calculated collection efficiency is 4% for a $0.001\text{-}\mu\text{m}$ -diameter particle, and decreases with increasing particle size.⁷ Thus, contamination of fogwater samples due to collection of submicron aerosol is effectively avoided. Anisokinetic sampling biases for very large droplet sizes depend considerably on the ambient wind speed. Wind speeds in radiation fogs are in general less than 2 m s^{-1} , but we have frequently found higher velocities (up to 10 m s^{-1}) in coastal advection fogs. Positive collection biases require ambient wind velocities $> 10 \text{ m s}^{-1}$, which could be found in clouds intercepting mountain slopes but are unlikely in other situations.

Perturbation of the ambient relative humidity during the sampling process may change the size of the fog droplets by condensation or evaporation and, therefore, affect chemical concentrations in the sample. Aerodynamic cooling as the droplets are accelerated at the inlet leads to condensation, and aerodynamic heating as the droplets are decelerated

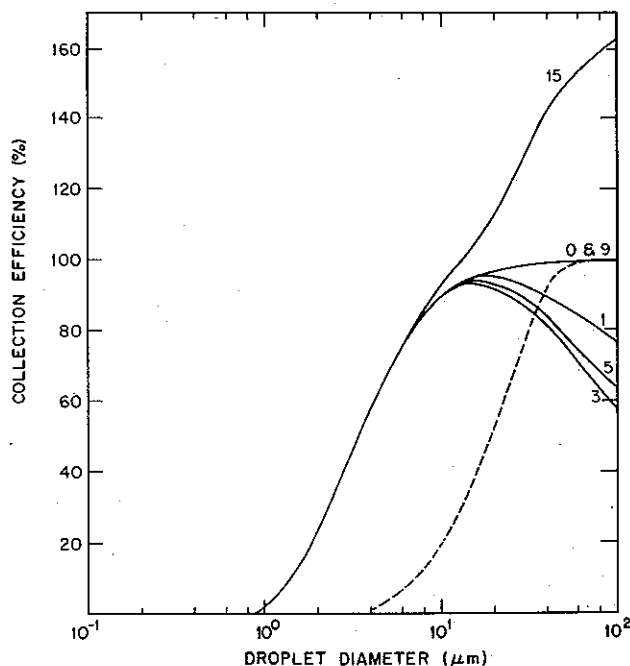

FIG. 2. Collection efficiency vs droplet diameter. Anisokinetic sampling biases are considered for an inlet oriented into the wind and various ambient wind velocities (m s^{-1}) indicated on the curves. No inlet bias occurs for $U_a = 0$ or $U_a = 9 \text{ m s}^{-1}$. Maximum negative bias occurs for $U_a \approx 3 \text{ m s}^{-1}$. Collection efficiencies in excess of 100% indicate positive sampling biases ($U_s < U_a$). Dashed line is the experimentally determined collection efficiency of the rotating arm collector. (Ref. 4).

TABLE I. Comparison of fogwater concentrations of samples collected simultaneously with the screen collector (SC) and the rotating arm collector (RAC) set side by side.^a

| | H ⁺ | Na ⁺ | Ca ²⁺ | Mg ²⁺ | NH ₄ ⁺ | Cl ⁻ | NO ₃ ⁻ | SO ₄ ⁻ |
|--------|----------------|-----------------|------------------|------------------|------------------------------|-------------------|--------------------------------|------------------------------|
| SC/RAC | 1.08 ± 0.11 | 0.71 ± 0.04 | 0.70 ± 0.10 | 0.71 ± 0.04 | 1.14 ± 0.14 | 0.93 ± 0.10 | 0.85 ± 0.06 | 0.99 ± 0.07 |
| | Fe | Pb | Mn | Ni | V | CH ₂ O | Fogwater Collection rate | |
| SC/RAC | 1.11 ± 0.34 | 1.12 ± 0.18 | 0.85 ± 0.28 | 1.05 ± 0.27 | 0.99 ± 0.12 | 1.04 ± 0.08 | 2.34 ± 0.24 | |

^a Comparison of four samples collected on 12 June 1984 at Henninger Flats (Ref. 12).

ated during approach to the strings leads to evaporation. To determine the extent of the resulting droplet size modification, we simultaneously solved the equations for flow field, relative humidity, droplet trajectory, and mass transfer, from equations previously derived.⁴ These calculations showed that no significant droplet growth or evaporation occurs for droplets larger than 1- μ m diameter. Therefore, droplet sizes are preserved at all stages of approach.

Evaporation on the strings must also be investigated. Aerodynamic heating near the strings leads to a localized subsaturation. Assuming that the compression is adiabatic, the maximum temperature gradient at the surface of the string is

$$\Delta T = \frac{(U_s \cos \theta)^2}{2C_p} \quad (3)$$

where C_p is the heat capacity of air. We find $\Delta T = 0.03$ K, which corresponds to a decrease in relative humidity of about 0.2%. More important as sources of thermodynamic modification are the fluctuations of the ambient relative humidity in fog: rapid oscillations of up to 1% relative humidity in amplitude have been reported in a radiation fog.¹³ Mass transfer calculations for a flow of air at 99% relative past a bank of cylinders¹⁴ indicate an overall rate of evaporation from the screens of 10^{-3} g min⁻¹. This is small compared to the collection rates achieved.

II. FIELD TESTING

The collector was first tested during a stratus cloud sampling program conducted on the mountain slopes above the Los Angeles basin.¹² Collection rates were in the range 0.5–1.5 ml min⁻¹. Four samples were collected simultaneously with the rotating arm collector, and the chemical compositions of the samples were compared (Table I). Concentrations were not significantly different between the two instruments, and usually within the errors previously documented between two rotating arm collectors set side by side.⁵

The similarity of compositions between samples collected by the screen collector and the rotating arm collector is striking, considering that the two instruments have very different collection efficiency vs droplet size characteristics (Fig. 2). A likely explanation is that most of the fogwater mass is present in a narrow droplet size window around 20- μ m diameter,¹² and that small fog droplets are not sufficient-

ly different in composition from the bulk fogwater to significantly affect the overall concentration. Small droplets have generally condensed on small nuclei and, therefore, are not systematically more concentrated than the larger droplets. The dependence of fog droplet composition on droplet size is an interesting question which has not been studied to date. Our collector could be conveniently used for such a study; different portions of the droplet size distribution could be sampled by using screens of different string diameters.

ACKNOWLEDGMENTS

Elton F. Daly and Joseph J. Fontana constructed the collector and offered valuable practical suggestions. We thank an anonymous reviewer for valuable comments. This work was funded by the California Air Resources Board.

¹ Present address: Center for Earth and Planetary Physics, Harvard University, Cambridge, Massachusetts.

² Present address: Department of Mechanical Engineering, Massachusetts Institute of Technology, Cambridge, Massachusetts.

³ To whom correspondence should be addressed.

⁴ H. R. Pruppacher and J. D. Klett, *Microphysics of Clouds and Precipitation* (Reidel, Dordrecht, 1978), pp. 141, 142, 418–421.

⁵ G. M. Lovett, *Atmos. Environ.* **18**, 361 (1984).

⁶ B. Hileman, *Environ. Sci. Technol. A* **17**, 117 (1983).

⁷ D. J. Jacob, R. -F. T. Wang, and R. C. Flagan, *Environ. Sci. Technol.* **18**, 827 (1984).

⁸ S. V. Hering and D. L. Blumenthal, Fog sampler intercomparison study: Final Report to Coordinating Research Council. Available from Coordinating Research Council, 219 Perimeter Center Parkway, Atlanta, GA, 1984.

⁹ J. G. Houghton and W. H. Radford, *Pap. Phys. Ocean. Met. Mass. Inst. Technol. Woods Hole Ocean. Instn.* **6**, 5-31 (1938).

¹⁰ S. K. Friedlander, *Smoke, Dust and Haze* (Wiley, New York, 1977), pp. 50–63 and 95–109.

¹¹ R. Israel and D. E. Rosner, *Aerosol Sci. Technol.* **2**, 45 (1983).

¹² P. N. Jasayekara and C. N. Davies, *J. Aerosol Sci.* **11**, 535 (1980).

¹³ C. N. Davies and M. Subari, *J. Aerosol Sci.* **13**, 59 (1982).

¹⁴ S. A. Self and R. L. Keating, HTGL Report No. 117, Department of Mechanical Engineering, Stanford University, Stanford, CA, 1980.

¹⁵ J. M. Waldman, Ph.D thesis, California Institute of Technology, Pasadena, California, 1985.

¹⁶ H. E. Gerber, *J. Atmos. Sci.* **38**, 454 (1981).

¹⁷ R. B. Bird, W. E. Stewart, and E. N. Lightfoot, *Transport Phenomena* (Wiley, New York, 1960), p. 646.